



# Coimisiún na Scrúduithe Stáit State Examinations Commission

---

**JUNIOR CERTIFICATE EXAMINATION, 2015**

---

**SCIENCE – ORDINARY LEVEL**

**THURSDAY, 11 JUNE – MORNING, 9.30 to 11.30**

---

## INSTRUCTIONS

1. Write your **examination number** in the box provided on this page.
2. Answer **all** questions.
3. Answer the questions in the spaces provided in this booklet. If you require extra space, there is a blank page provided at the back of this booklet.
4. The use of the *Formulae and Tables* booklet approved for use in the State Examinations is permitted. A copy may be obtained from the examination superintendent.

<p><b>Centre Number</b></p>
-----------------------------

<p><b>Examination Number</b></p> <hr style="width: 20%; margin: 10px auto;"/>
---

For examiner use only	
Section / Question	Mark
<b>Biology</b>	
Q.1 (52)	
Q.2 (39)	
Q.3 (39)	
<b>Chemistry</b>	
Q.4 (52)	
Q.5 (39)	
Q.6 (39)	
<b>Physics</b>	
Q.7 (52)	
Q.8 (39)	
Q.9 (39)	
<b>Total (Paper)</b>	
Bonus for Irish	
<b>Grand Total (Paper) (390)</b>	
<b>Coursework A (60)</b>	
<b>Coursework B (150)</b>	
<b>Grand Total (600)</b>	

# Biology

For  
examiner  
use only

## Question 1

(52)

(1) (2)

- (a) Reproduction is a characteristic common to all living things. List two other characteristics of living things.

1. \_\_\_\_\_ 2. \_\_\_\_\_

- (b) The diagrams show sections through three types of blood vessel found in humans.

- (i) In the table write the letter **A** beside the artery.

- (ii) Write the letter **V** beside the vein.

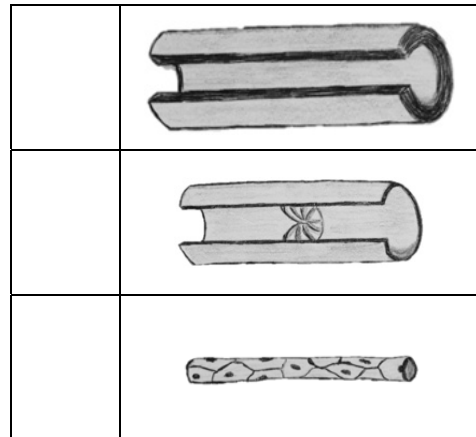

- (c)(i) In the table write the letter **P** beside the average resting human pulse rate.

- (ii) Write the letter **C** beside the change that happens to the pulse rate during exercise.

	<b>37 b.p.m.</b>
	<b>70 b.p.m.</b>
	<b>Increase</b>
	<b>Decrease</b>

- (d) Protein is found in many foods, such as milk and eggs.

- (i) Name a chemical used in the laboratory to test for the presence of protein in food.

\_\_\_\_\_

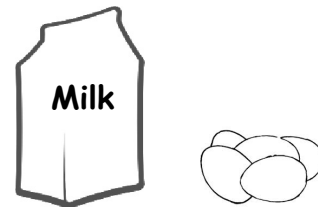

- (ii) Write the letter **C** beside the colour produced if protein is present in the food sample.

	<b>Yellow</b>
	<b>Purple</b>

(e) Food pyramids are used as guidelines to the amounts of different foods we should eat each day.

(i) Write the letter **X** on the food pyramid to show where starchy foods are found.

(ii) Write the letter **Y** on the food pyramid to show where the foods that should be eaten in small amounts are found.

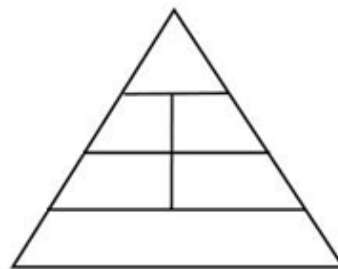

(1) (2)

(f) Name the process by which the leaves of a plant make food using light as a source of energy.

\_\_\_\_\_



(g) From the underlined words in the sentence below choose the *enzyme* and the *product* of the reaction.

“During chemical digestion in the mouth amylase acts on starch and the sugar maltose is formed.”

(i) The enzyme is \_\_\_\_\_.

(ii) The product is \_\_\_\_\_.

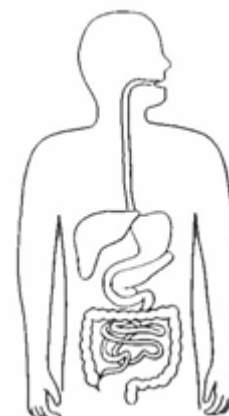

(h) To test a leaf for the presence of starch, the leaf is first boiled in water to kill it. The leaf is then placed in liquid **X** to remove its chlorophyll.

(i) Name liquid **X** which is used to remove the chlorophyll from the leaf. \_\_\_\_\_

(ii) Identify this safety symbol, which is found on the bottle containing liquid **X**.  
\_\_\_\_\_



(iii) What safety precaution should you take when using this liquid?  
\_\_\_\_\_

(7 × 6 + 1 × 10)

**Question 2**

(39)

For  
examiner  
use only

(a) The diagram shows the human female reproductive system.

(21)

(1) (2)

(i) In the table write the letter **A** beside the name of the part labelled **A**.

(ii) Write the letter **B** beside the name of the part labelled **B**.

(iii) Write the letter **C** beside the name of the part labelled **C**.

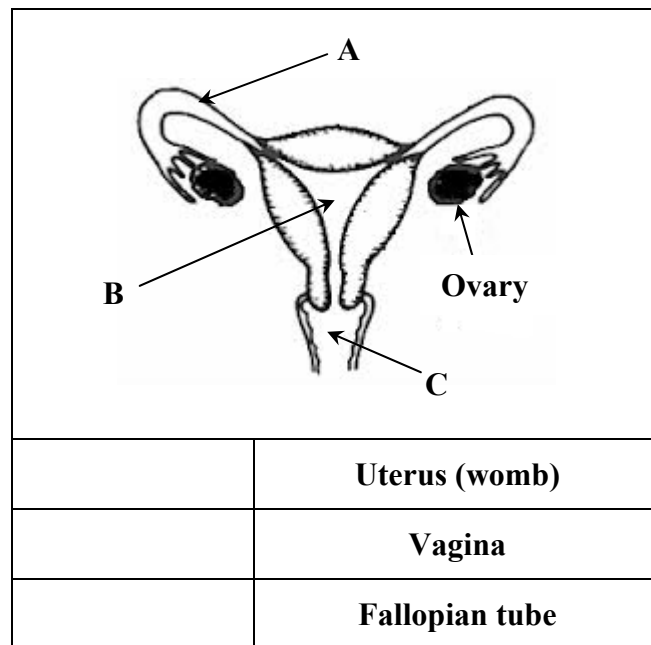

(iv) Give one function of the ovary.

\_\_\_\_\_

(v) In which of the labelled parts **A**, **B** or **C** does fertilisation usually occur?

\_\_\_\_\_

(vi) Name one method of contraception.

\_\_\_\_\_

(b) The diagram shows the human breathing system.

(18)

For  
examiner  
use only

(1) (2)

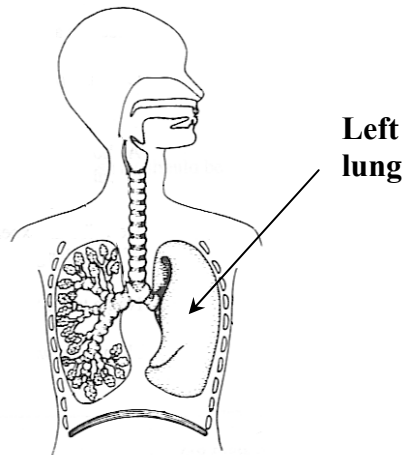

(i) Describe one effect that smoking has on the human breathing system.

\_\_\_\_\_

(ii) Name the part of the human skeleton that protects the lungs.

\_\_\_\_\_

(iii) Choose the correct words from the box to complete the following sentences.

“During gas exchange \_\_\_\_\_  
is taken from the lungs into the bloodstream.”

“During gas exchange \_\_\_\_\_  
is taken from the bloodstream into the lungs.”

<b>Carbon dioxide</b>
<b>Oxygen</b>
<b>Nitrogen</b>

(iv) Plants also carry out gas exchange.

Name the parts of the plant labelled **A** and **B**.

**A** \_\_\_\_\_

**B** \_\_\_\_\_

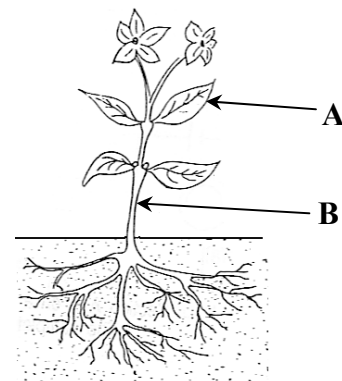

**Question 3**

(39)

For  
examiner  
use only

- (a) A student carried out a survey of the plants in a grassland habitat. The table shows the results of the survey. (15)

(1) (2)

Plant	Grass	Clover	Daisy	Buttercup
Frequency	100	30	60	50

- (i) Use this data to draw a bar chart of the frequency for each plant on the grid provided below.

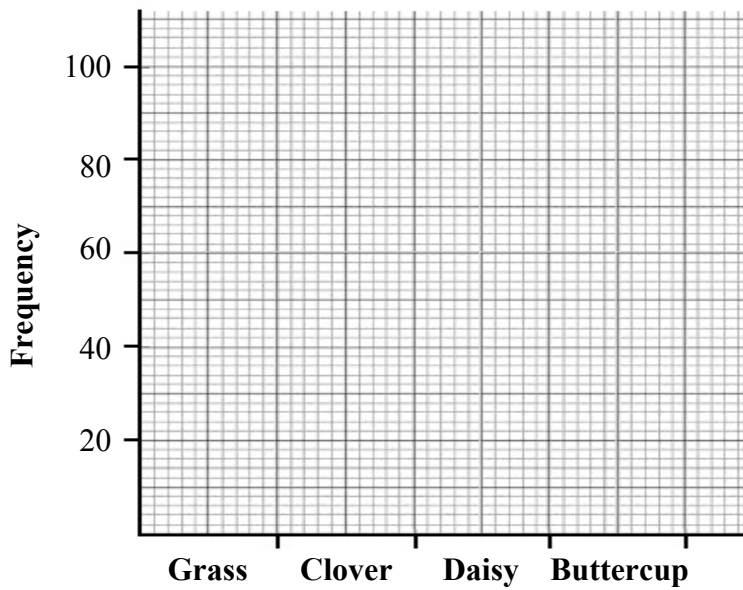

- (ii) Name a plant that has a lower frequency than the daisy. \_\_\_\_\_

- (iii) Name a piece of equipment the student may have used during the survey.

\_\_\_\_\_

- (b) Suggest one example of how human activity can have a positive effect on the environment and one example of how human activity can have a negative effect on the environment. (6)

Positive effect \_\_\_\_\_

\_\_\_\_\_

Negative effect \_\_\_\_\_

\_\_\_\_\_

(c) The photograph shows a sterile nutrient agar dish that can be used when investigating the presence of micro-organisms in air and in soil. (18)

(i) What is the purpose of the nutrients in the nutrient agar?

\_\_\_\_\_

\_\_\_\_\_

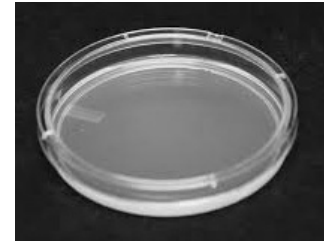

(ii) The dishes must be *sterile* before the experiment.

In the table write the letter **S** beside the meaning of the word “sterile”.

	<b>Micro-organisms are growing in the dishes</b>
	<b>No living micro-organisms are present in the dishes</b>

(iii) Describe how micro-organisms could be added to the dishes from the air and from the soil.

Air \_\_\_\_\_

\_\_\_\_\_

Soil \_\_\_\_\_

\_\_\_\_\_

(iv) One sterile nutrient agar dish was used as a control.

What is a control?

\_\_\_\_\_

\_\_\_\_\_

\_\_\_\_\_

(v) The dishes must be incubated to allow the micro-organisms to grow.

Write the letter **T** beside the temperature that is suitable for the incubation.

	<b>30 °C</b>
	<b>100 °C</b>

For  
examiner  
use only

(1) (2)

# Chemistry

For  
examiner  
use only

## Question 4

(52)

(1) (2)

(a) In the laboratory a student drops hydrochloric acid onto marble chips (calcium carbonate) and collects the gas that is released.

(i) Name the gas. \_\_\_\_\_

(ii) Write the letter **T** beside the test that is used to confirm the presence of this gas.

	<b>Limewater turns milky</b>
	<b>Limewater turns green</b>

(b) There are three states of matter: solid, liquid and gas.

Write the letter **S** beside the two characteristics that all solids have in common.

	<b>Has a fixed shape</b>
	<b>No fixed shape</b>
	<b>Has a fixed volume</b>
	<b>No fixed volume</b>

(c) From the list below select the two processes that are carried out during the treatment of water before it is pumped to our homes.

**Chlorination**

**Condensation**

**Filtration**

**Reduction**

1. \_\_\_\_\_ 2. \_\_\_\_\_

(d) The diagram shows the apparatus used to carry out distillation of sea water.

(i) Name the piece of equipment that should be placed at **X**. \_\_\_\_\_

(ii) What would you expect to find in the beaker when the distillation is complete?  
\_\_\_\_\_

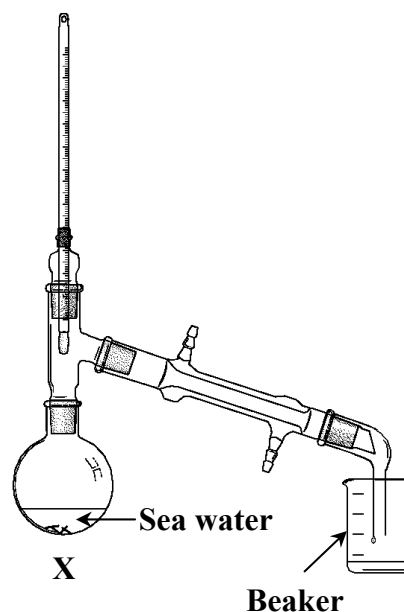



(e)(i) Write the letter **W** beside a chemical that can be used to test for the presence of water.

	<b>Anhydrous copper sulfate</b>
	<b>Calcium carbonate</b>
	<b>Cobalt chloride</b>

For  
examiner  
use only

(1) (2)

(ii) What colour does this chemical turn in water? \_\_\_\_\_

(f) Carbon dioxide is one of the gases found in air.

(i) Is carbon dioxide more dense *or* less dense than air? \_\_\_\_\_

(ii) Carbon dioxide has a number of uses.

State one use of carbon dioxide.

\_\_\_\_\_

(g) The table shows the charges of sub-atomic particles.

(i) Write the letter **P** beside the charge of a proton.

	<b>Negative</b>
	<b>Neutral</b>
	<b>Positive</b>

(ii) Write the letter **E** beside the charge of an electron.

(h) Water has the chemical formula **H<sub>2</sub>O**.

(i) Name the two elements in water.

Element 1 \_\_\_\_\_

Element 2 \_\_\_\_\_

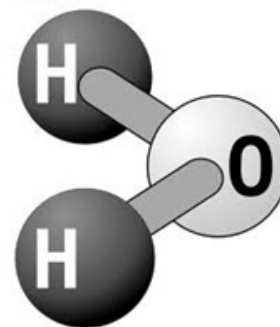

(ii) Atoms in a water molecule are held together by bonds formed when the atoms share pairs of electrons with each other.

Name this type of bond.

\_\_\_\_\_

(7 × 6 + 1 × 10)

**Question 5**

(39)

For  
examiner  
use only

(a)(i) Choose the alloy from the list on the right.

\_\_\_\_\_

- |               |
|---------------|
| <b>Copper</b> |
| <b>Bronze</b> |
| <b>Tin</b>    |

(9)

(1) (2)

(ii) Describe one use for this alloy.

\_\_\_\_\_

(iii) Is an alloy a mixture *or* a compound? \_\_\_\_\_

(b) The diagram shows a separation technique used to examine a variety of inks. (18)

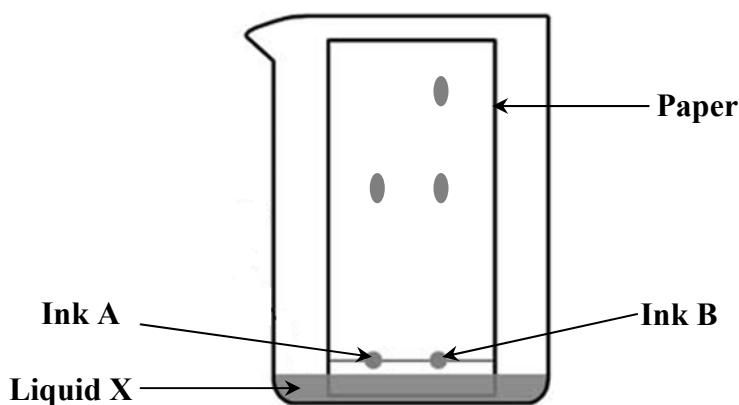

(i) Choose the name of this separation technique from the list on the right. \_\_\_\_\_

- |                       |
|-----------------------|
| <b>Chromatography</b> |
| <b>Filtration</b>     |

(ii) Name a liquid that could be used as liquid X. \_\_\_\_\_

(iii) Why are the ink spots **A** and **B** placed above the liquid?

\_\_\_\_\_

(iv) Which of the inks, **A** *or* **B**, is made of more than one colour? \_\_\_\_\_

Give a reason for your answer.

\_\_\_\_\_

(c) Describe, with the aid of a labelled diagram, how you would show that approximately one fifth of the air is oxygen.

(12)

The headings below may be helpful.

Labelled diagram

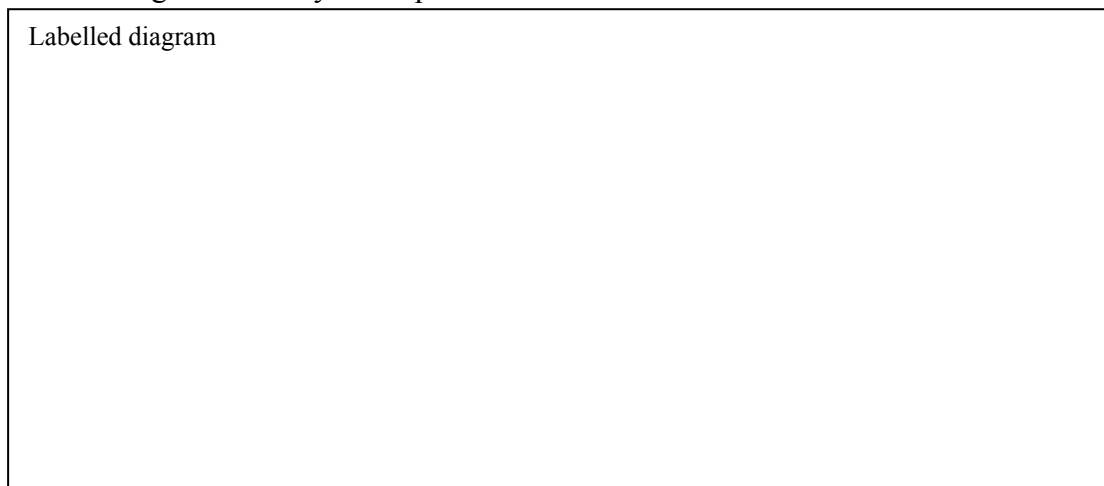

Equipment: \_\_\_\_\_

\_\_\_\_\_

\_\_\_\_\_

\_\_\_\_\_

Procedure: \_\_\_\_\_

\_\_\_\_\_

\_\_\_\_\_

\_\_\_\_\_

\_\_\_\_\_

\_\_\_\_\_

\_\_\_\_\_

\_\_\_\_\_

Result: \_\_\_\_\_

\_\_\_\_\_

\_\_\_\_\_

\_\_\_\_\_

For  
examiner  
use only

(1) (2)

**Question 6**

(39)

For  
examiner  
use only

- (a) The diagram shows the equipment used in a titration experiment in which an acid and a base react with each other. (18)

(1) (2)

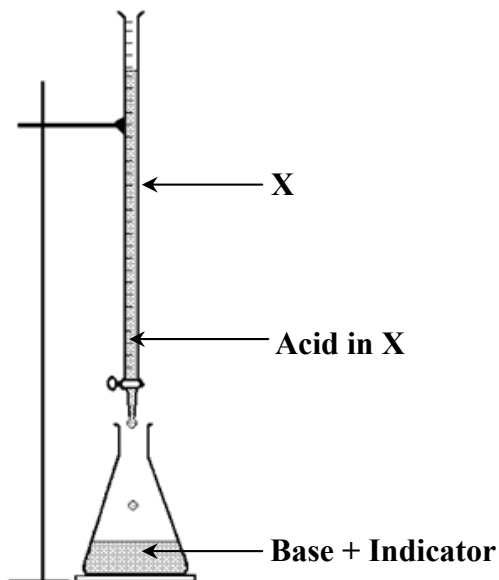

(i) Name the piece of equipment labelled X. \_\_\_\_\_

(ii) What is the purpose of the indicator?  
\_\_\_\_\_  
\_\_\_\_\_

(iii) The acid and base react to form sodium chloride and water.

Write the letter **A** beside the acid that was used.

Write the letter **B** beside the base that was used.

	<b>Hydrochloric acid</b>
	<b>Sulfuric acid</b>
	<b>Sodium hydroxide</b>
	<b>Calcium carbonate</b>

(iv) Choose the method you would use to separate the sodium chloride from the water after the titration.

\_\_\_\_\_

<b>Corrosion</b>
<b>Evaporation</b>

(b) The diagram shows the production of oxygen.

(21)

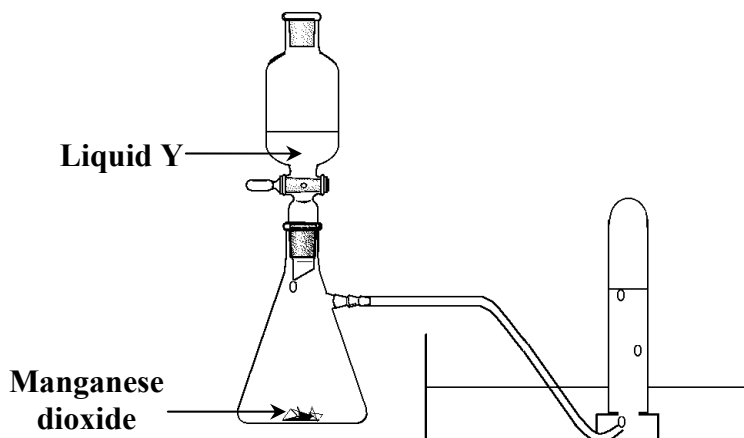

For  
examiner  
use only

(1) (2)

Manganese dioxide is the catalyst in this experiment.

(i) What colour is manganese dioxide, black *or* red? \_\_\_\_\_

(ii) What is a catalyst?

\_\_\_\_\_  
\_\_\_\_\_

(iii) Name liquid Y. \_\_\_\_\_

(iv) Describe how a student could show that the gas produced is oxygen.

\_\_\_\_\_  
\_\_\_\_\_

(v) Magnesium burns in oxygen to make magnesium oxide.

Describe the flame produced when magnesium burns in oxygen.

\_\_\_\_\_

Write the letter **E** beside the effect that the magnesium oxide has on moist litmus paper.

	<b>The colour changes from blue to red</b>
	<b>The colour changes from red to blue</b>

# Physics

For  
examiner  
use only

## Question 7

(52)

(1) (2)

- (a) The diagram shows a bar magnet.  
Draw the pattern of the magnetic field you would notice if iron filings or plotting compasses were placed around the bar magnet.



- (b) A box weighing 20 N is lifted up a distance of 5 m.
- (i) Write the letter **W** beside the amount of work done.
- (ii) Write the letter **X** beside the unit of measurement for work.

	<b>4</b>
	<b>100</b>
	<b>Watt (W)</b>
	<b>Joule (J)</b>

- (c) The picture shows a see-saw, which is an example of a lever.

- (i) Write the letter **F** at the location of the fulcrum (turning point).

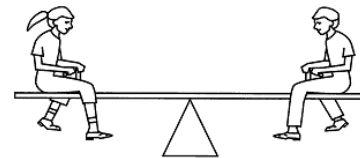

- (ii) Give another everyday example of a lever.

---

- (d)(i) What would you notice about the sound of the bell in the picture on the right after the vacuum pump is turned on? \_\_\_\_\_

- (ii) What does this tell us about sound?

---



---

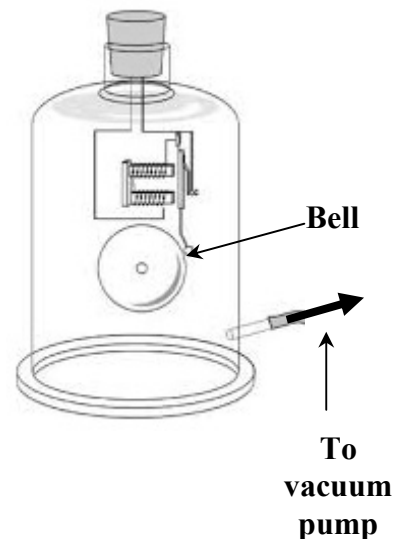

(e) The force of friction acts in many places in a car.

(i) How does the size of the friction change when the driver pushes the brake pedal?



\_\_\_\_\_

(ii) How does the size of the friction between the tyres and the road change when the road is covered in ice?

\_\_\_\_\_

(f) The diagram shows equipment that can be used in the laboratory to examine the effect of heat on a metal. Describe how it is used.

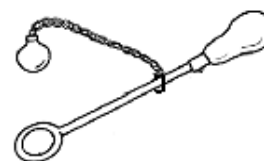

\_\_\_\_\_  
\_\_\_\_\_

(g)(i) How does atmospheric pressure change as you climb up a mountain?

\_\_\_\_\_

(ii) How does the boiling point of water change when atmospheric pressure is decreased?

\_\_\_\_\_

(h)(i) Complete the following sentence using words from the box.

“Convection is the transfer of heat through a \_\_\_\_\_ or a \_\_\_\_\_.”

<p><b>Solid</b> <b>Liquid</b> <b>Gas</b></p>
--

(ii) Food dye has been added to the water to show the direction of movement of heat.

Would you expect the food dye to move in direction **A** or in direction **B** when the Bunsen burner is turned on?

\_\_\_\_\_

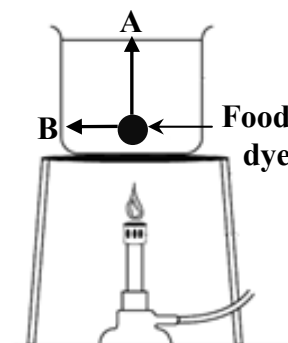

(7 × 6 + 1 × 10)

**Question 8**

(39)

For  
examiner  
use only

(a) In the laboratory it is important to be able to take accurate measurements. (12)

(1) (2)

(i) Name a piece of equipment that is used to accurately measure the volume of a liquid.

\_\_\_\_\_

A fixed volume of liquid water is frozen to form an ice cube with edges of length 2 cm.

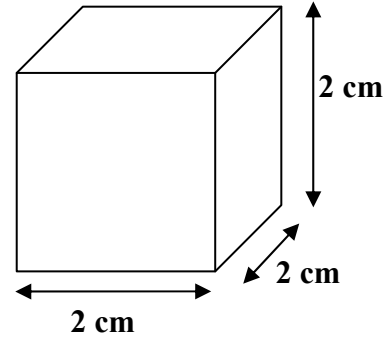

(ii) Calculate the volume of the ice cube.

Calculation
-------------

(iii) State the units that are used to measure the volume. \_\_\_\_\_

(iv) Write the letter **V** beside the correct statement below.

	<b>The volume of the ice cube is less than the volume of the liquid water</b>
	<b>The volume of the ice cube is the same as the volume of the liquid water</b>
	<b>The volume of the ice cube is greater than the volume of the liquid water</b>

(b) The pressure in a liquid changes with depth. (9)

(i) The diagram shows a bottle of water with three identical holes punched at different levels. The water can be seen coming from hole **B**. Draw the path of water that you would expect to see coming out of the bottle at hole **A** and hole **C**.

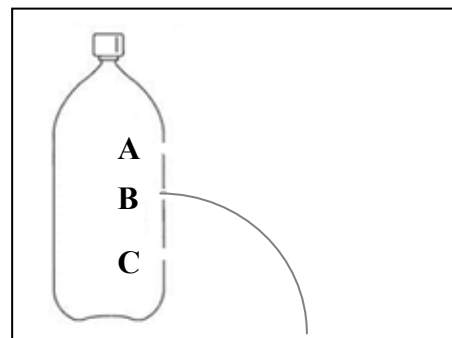

(ii) A scuba diver swims slowly down through the water. How does the pressure of the water change as he moves downwards?

\_\_\_\_\_

\_\_\_\_\_





(c) The Sun is the primary source of energy on Earth.

(18)

(i) Complete the sentence below using one of the words in the box.

**Conduction**  
**Radiation**  
**Convection**

“Heat travels from the Sun to the Earth by \_\_\_\_\_.”

(ii) When light shines on an object a shadow may form, as shown in the diagram.

Explain how the shadow of the object is formed on the piece of card.

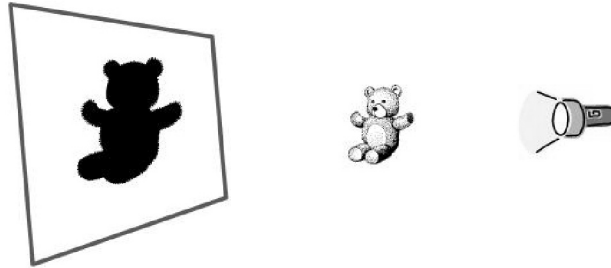

---

---

(iii) When light hits a mirror it is reflected. Explain the underlined word.

---

(iv) The diagram below shows one ray of light hitting a mirror. Complete the diagram to show where the ray travels after it hits the mirror.

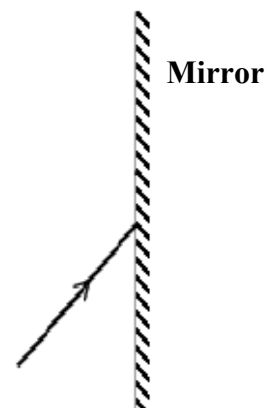

(v) Describe one example of how reflection of light is useful in everyday life.

---

---

For  
examiner  
use only

(1) (2)

**Question 9**

(39)

For  
examiner  
use only

(a) The circuit on the right shows two bulbs, a battery and a switch. (9)

(i) Are the two bulbs connected in series *or* in parallel? \_\_\_\_\_

(ii) Both bulbs light up when the switch is closed. After a few minutes bulb **A** blows (goes out). What happens to bulb **B** at this time?

\_\_\_\_\_

(iii) Is the current from the battery a.c. *or* d.c.? \_\_\_\_\_

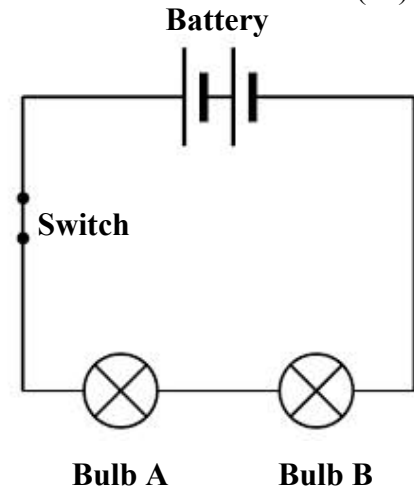

(1) (2)

(b) An electric kettle is shown in the photograph. (12)

(i) Complete the sentence below using one of the words in the box.

“An electric kettle is used to boil water and this shows the conversion of electrical energy into \_\_\_\_\_ energy.”



**Chemical  
Heat**

(ii) What is the purpose of the fuse in the plug of the kettle?

\_\_\_\_\_

(iii) The kettle has a power rating of 2 kW. It is used to boil water for 3 hours.

Calculate the number of units of electricity (kWh) the kettle uses.

Calculation
-------------

(iv) The cost of using one unit of electricity is 18 cent.

Calculate the cost of electricity for using the kettle.

Calculation
-------------

- (c) A student carried out an experiment to investigate the relationship between light intensity and resistance in a circuit containing a light-dependent resistor (LDR). (12)

On the left is some of the equipment the student used.

On the right is the graph of the results the student obtained.

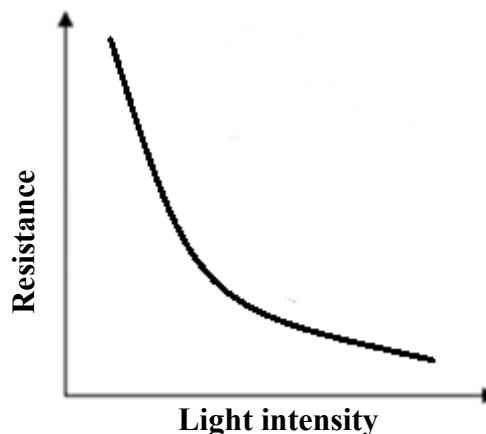
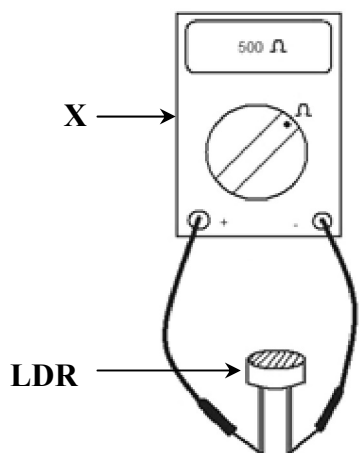

- (i) How would the student vary the light intensity shining on the LDR?

---

- (ii) Name the piece of equipment labelled X, which is used to measure resistance.

---

- (iii) From the graph state how resistance changes as light intensity increases.

---

- (iv) Describe one way that an LDR can be used in everyday life.

---



---

- (d) Complete the sentences below using the words in the box. (6)

- (i) “Static electricity gathers on some objects when they are \_\_\_\_\_.”

- (ii) “Static electricity is lost from an object when it is \_\_\_\_\_.”

<p><b>Rubbed</b> <b>Earthed</b></p>
---

