



**Coimisiún na Scrúduithe Stáit  
State Examinations Commission**

---

**LEAVING CERTIFICATE EXAMINATION, 2010**

---

**PHYSICS – HIGHER LEVEL**

---

**MONDAY, 21 JUNE – MORNING, 9:30 to 12:30**

---

Answer **three** questions from **Section A** and **five** questions from **Section B**.

---

## SECTION A (120 marks)

Answer **three** questions from this section.

Each question carries 40 marks.

1. In an experiment to investigate the relationship between the acceleration of a body and the force applied to it, a student recorded the following data.

$F/\text{N}$	0.20	0.40	0.60	0.80	1.00	1.20	1.40
$a/\text{m s}^{-2}$	0.08	0.18	0.28	0.31	0.45	0.51	0.60

Describe the steps involved in measuring the acceleration of the body. (12)

Using the recorded data, plot a graph to show the relationship between the acceleration of the body and the force applied to it.

What does your graph tell you about this relationship? (16)

Using your graph, find the mass of the body. (6)

On a trial run of this experiment, a student found that the graph did not go through the origin. Suggest a reason for this and describe how the apparatus should be adjusted, so that the graph would go through the origin. (6)

2. In an experiment to measure the specific latent heat of vaporisation of water, a student used a copper calorimeter containing water and a sensitive thermometer. The water was cooled below room temperature before adding dry steam to it.

The following measurements were recorded.

Mass of copper calorimeter	=	34.6 g
Initial mass of calorimeter and water	=	96.4 g
Mass of dry steam added	=	1.2 g
Initial temperature of calorimeter and cooled water	=	8.2 °C
Final temperature of calorimeter and water	=	20.0 °C

How was the water cooled below room temperature? (6)

How was the steam dried? (6)

Describe how the mass of the steam was determined. (6)

Why was a sensitive thermometer used? (6)

Using the data, calculate the specific latent heat of vaporisation of water. (16)

(specific heat capacity of water =  $4180 \text{ J kg}^{-1} \text{ K}^{-1}$ ; specific heat capacity of copper =  $390 \text{ J kg}^{-1} \text{ K}^{-1}$ )

3. In an experiment to verify Snell's law, a student recorded the following data.

$i/^\circ$	30	40	50	55	60	65	70
$r/^\circ$	19	26	30	33	36	38	40

Draw a labelled diagram of the apparatus used.

On your diagram, indicate an angle  $i$  and its corresponding angle  $r$ . (12)

Using the recorded data, draw a suitable graph and explain how your graph verifies Snell's law.

Using your graph, calculate the refractive index of the substance used in the experiment. (22)

The student did not record any values of the angle  $i$  below  $30^\circ$ . Give two reasons why. (6)

4. In an experiment to investigate the variation of the resistance  $R$  of a thermistor with its temperature  $\theta$ , a student measured its resistance at different temperatures.

The table shows the measurements recorded.

$\theta/^\circ\text{C}$	20	30	40	50	60	70	80
$R/\Omega$	2000	1300	800	400	200	90	40

Draw a labelled diagram of the apparatus used. (9)

How was the resistance measured? (6)

Describe how the temperature was varied. (6)

Using the recorded data, plot a graph to show the variation of the resistance of a thermistor with its temperature.

Use your graph to estimate the average variation of resistance per kelvin in the range  $45^\circ\text{C} - 55^\circ\text{C}$ . (15)

In this investigation, why is the thermistor usually immersed in oil rather than in water? (4)

## SECTION B (280 marks)

Answer **five** questions from this section.  
Each question carries 56 marks.

---

5. Answer any **eight** of the following parts (a), (b), (c), etc.

- (a) What are the two conditions for the equilibrium of a set of co-planar forces? (7)
- (b) What is the critical angle of a sample of glass whose refractive index is 1.46? (7)
- (c) Name the parts labelled **A** and **B** of the spectrometer shown in the diagram. (7)

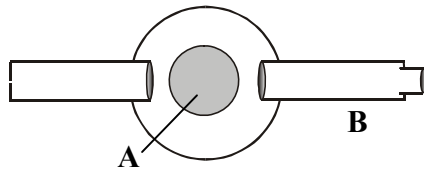

- (d) Explain why snow is slow to melt as the air temperature rises above  $0^{\circ}\text{C}$ . (7)
- (e) What is the positive charge stored on a  $5\ \mu\text{F}$  capacitor when it is connected to a  $120\ \text{V}$  d.c. supply? (7)
- (f) Which one of the following devices is adjusted when tuning a radio: transformer, diode, capacitor, rheostat? (7)
- (g) State Faraday's law of electromagnetic induction. (7)
- (h) The peak voltage of an a.c. supply is  $300\ \text{V}$ . Calculate its rms voltage. (7)
- (i) Name the naturally occurring radioactive gas which seeps into buildings from underground rocks and which can cause lung cancer. (7)
- (j) Give two advantages of a circular accelerator over a linear accelerator.  
**or**  
State the principle of a moving-coil galvanometer. (7)

6. State Newton's law of universal gravitation.

Use this law to calculate the acceleration due to gravity at a height above the surface of the earth, which is twice the radius of the earth.

(18)

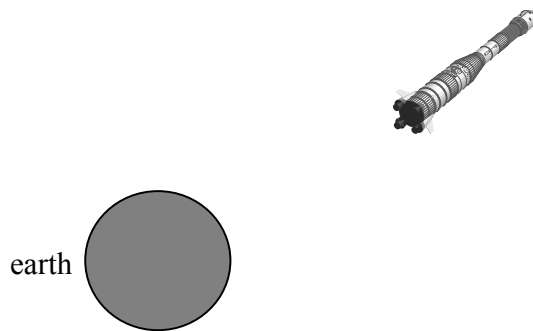

A spacecraft carrying astronauts is on a straight line flight from the earth to the moon and after a while its engines are turned off.

- (i) Explain why the spacecraft continues on its journey to the moon, even though the engines are turned off. (6)
- (ii) Describe the variation in the weight of the astronauts as they travel to the moon. (6)
- (iii) At what height above the earth's surface will the astronauts experience weightlessness? (12)
- (iv) The moon orbits the earth every 27.3 days.  
What is its velocity, expressed in metres per second? (9)
- (v) Why is there no atmosphere on the moon? (5)

(Radius of the earth =  $6.36 \times 10^6$  m

Acceleration due to gravity at the earth's surface =  $9.81 \text{ m s}^{-2}$

Distance from the centre of the earth to the centre of the moon =  $3.84 \times 10^8$  m

Assume the mass of the earth is 81 times the mass of the moon.)

7. The Doppler effect applies to all types of waves and is named after Christian Johann Doppler, an Austrian scientist who explained this phenomenon in 1842.



What is the Doppler effect?

Explain, with the aid of labelled diagrams, how this phenomenon occurs. (18)

Describe a laboratory experiment to demonstrate the Doppler effect. (9)

In the early part of the twentieth century, Hubble and other astronomers made the first measurements on the spectra from distant stars. They observed that these spectra were shifted and they used the Doppler effect to explain these shifts.

What causes the red shift in the spectrum of a distant star? (6)

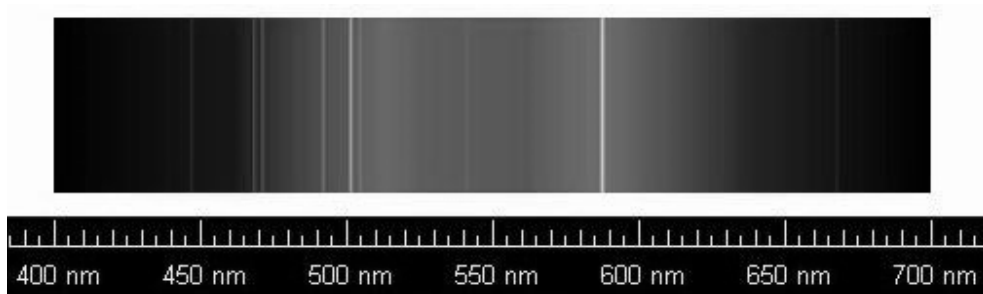

The yellow line emitted by a helium discharge tube in the laboratory has a wavelength of 587 nm as shown in the diagram. The same yellow line in the helium spectrum of a star has a measured wavelength of 590 nm.

What can you deduce about the motion of the star?

Calculate the speed of the moving star. (18)

Give another application of the Doppler effect. (5)

(speed of light =  $3.00 \times 10^8 \text{ m s}^{-1}$ )

8. A hair dryer with a plastic casing uses a coiled wire as a heat source. When an electric current flows through the coiled wire, the air around it heats up and a motorised fan blows the hot air out.



What is an electric current?

Heating is one effect of an electric current.

Give two other effects of an electric current. (12)

The diagram shows a basic electrical circuit for a hair dryer.

- (i) Describe what happens:
- (a) when switch **A** is closed and the rheostat is adjusted
- (b) when switch **A** and switch **B** are closed. (9)
- (ii) The maximum power generated in the heating coil is 2 kW.
- (a) What is the initial resistance of the coil?
- (b) Calculate the current that flows through the coil when the dryer is turned on. (9)
- (iii) A length of nichrome wire of diameter 0.17 mm is used for the coil. Calculate the length of the coil of wire. (18)
- (iv) Explain why the current through the coil would decrease if the fan developed a fault and stopped working. (8)
- (resistivity of nichrome =  $1.1 \times 10^{-6} \Omega \text{ m}$ )

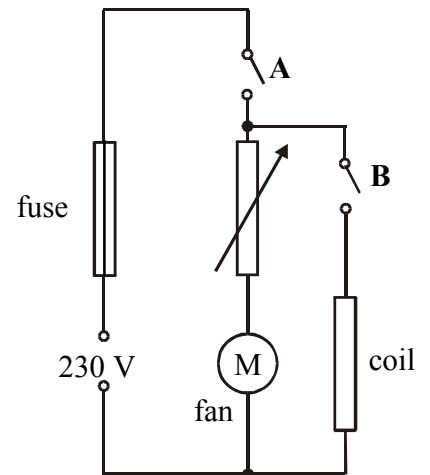

9. What is thermionic emission? (6)

X-rays are produced when high-energy electrons collide with a target.

Draw a labelled diagram of an X-ray tube. (12)

What are X-rays and how do they differ from light rays?

Give two uses of X-rays. (18)

When electrons hit the target in an X-ray tube, only a small percentage of their energy is converted into X-rays. What happens to the rest of their energy and how does this influence the type of target used? (9)

A potential difference (voltage) of 40 kV is applied across an X-ray tube.

Calculate:

- (i) the maximum energy of an electron as it hits the target
- (ii) the frequency of the most energetic X-ray produced. (11)

(Planck constant =  $6.6 \times 10^{-34} \text{ J s}$  ; charge on electron =  $1.6 \times 10^{-19} \text{ C}$ )

10. Answer **either** part (a) **or** part (b).



(a) The history of anti-matter begins in 1928 when a young English physicist named **Paul Dirac** predicted an anti-particle for the electron.

(i) What is anti-matter?

An anti-matter particle was first discovered during the study of cosmic rays in 1932. Name the anti-particle and give its symbol.

What happens when a particle meets its anti-particle? (18)

(ii) What is meant by pair production?

A photon of frequency  $3.6 \times 10^{20}$  Hz causes pair production.

Calculate the kinetic energy of one of the particles produced, each of which has a rest mass of  $9.1 \times 10^{-31}$  kg. (21)

(iii) A member of a meson family consists of two particles.

Each particle is composed of up and down quarks and their anti-particles.

Construct the possible combinations.

Deduce the charge of each combination and identify each combination.

What famous Irish writer first thought up the name 'quark'? (17)

(speed of light =  $3.0 \times 10^8$  m s<sup>-1</sup>; Planck constant =  $6.6 \times 10^{-34}$  J s)

(b) Distinguish between intrinsic conduction and extrinsic conduction in a semiconductor. (9)

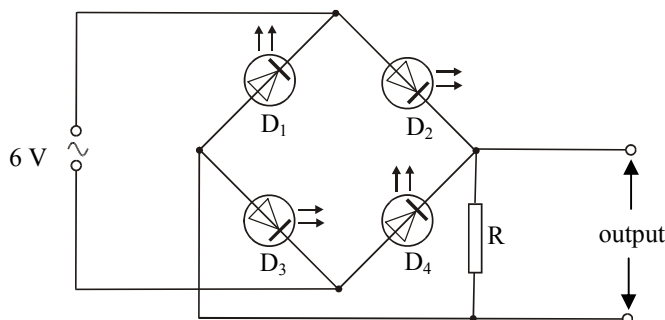

The circuit shows four light-emitting diodes connected to a resistor R and a 6 V a.c. supply of frequency 1 Hz.

(i) What is observed when the circuit is operating?

Explain what is observed by referring to the circuit.

What is observed when the frequency of the a.c. supply is increased to 50 Hz? (18)

(ii) Give two functions of the resistor R?

How was the output voltage displayed?

Draw graphs to show the differences between the input voltage and the output voltage. (24)

(iii) It is noticed that the output voltage is lower than the input voltage. Explain why. (5)



11. Read the following passage and answer the accompanying questions.

A person's exposure to radiation when using a mobile phone is measured in terms of the Specific Absorption Rate (SAR). This is a measure of the rate at which radio frequency energy is absorbed by a person's body during a phone call and is expressed in watts per kilogram.

A radio frequency wave penetrates the body to a depth that depends on its frequency. At mobile phone frequencies the wave energy is absorbed by about one centimetre of body tissue. The energy absorbed is converted into heat and is carried away by the body. Any adverse health effects from radio frequency waves are due to heating. Current scientific evidence indicates that exposure to radiation from mobile phones is unlikely to induce cancer.



*(Adapted from a Dept. of Communications, Energy and Natural Resources Press Release of 22 March 2007.)*

- (a) Give two properties of radio waves. (7)
- (b) In a three-minute phone call, 10 g of head tissue absorbs 0.36 J of radio frequency energy. Calculate the SAR value. (7)
- (c) What happens to the radio frequency energy absorbed by the body? (7)
- (d) Why are radio frequency waves not very penetrating? (7)
- (e) A mobile phone converts the received radio frequency waves to sound waves. What are the audible frequency limits for sound waves? (7)
- (f) Give two safety precautions you should take when using a mobile phone. (7)
- (g) A mobile phone transmits at 1200 MHz from its antenna. Calculate the length of its antenna, which is one quarter of the wavelength that it transmits. (7)
- (h) Name an electromagnetic wave which may induce cancer. Justify your answer. (7)

(speed of light =  $3.0 \times 10^8$  m s<sup>-1</sup>)

12. Answer any **two** of the following parts (a), (b), (c), (d).

- (a) (i) A student holds a motion sensor attached to a data-logger and its calculator. List the instructions you should give the student so that the calculator will display the graph shown in **Figure 1**. (14)

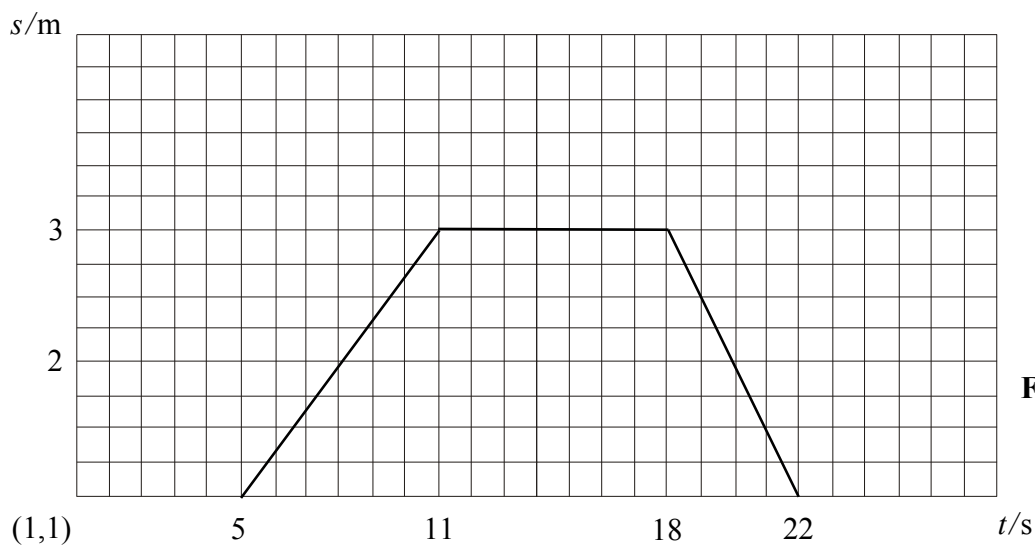

**Figure 1**

- (ii) The graph in **Figure 2** represents the motion of a cyclist on a journey.

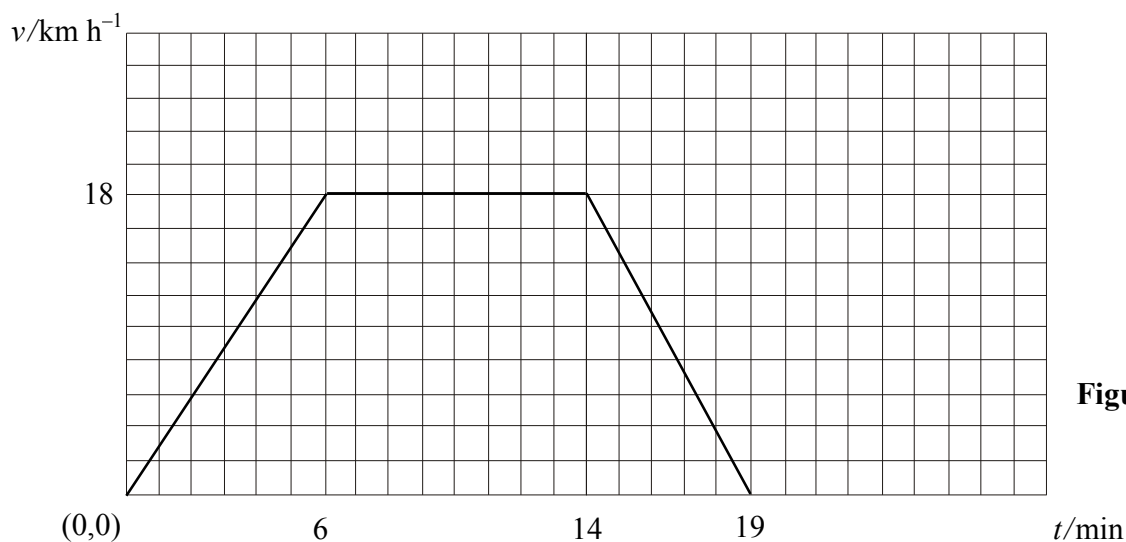

**Figure 2**

Using the graph, calculate the distance travelled by the cyclist and the average speed for the journey. (14)

(b) The following reaction occurs in a nuclear reactor:

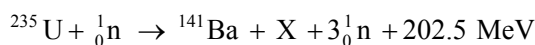

- (i) Identify the element X. (6)
- (ii) Calculate the mass difference between the reactants and the products in the reaction. (9)
- (iii) What is a chain reaction?  
Give one condition necessary for a chain reaction to occur. (9)
- (iv) Give one environmental impact associated with a nuclear reactor. (4)

(speed of light =  $3.0 \times 10^8 \text{ m s}^{-1}$ ;  $1\text{eV} = 1.6 \times 10^{-19} \text{ J}$ )

(c) Explain the term resonance and describe a laboratory experiment to demonstrate it. (15)

Give two characteristics of a musical note and name the physical property on which each characteristic depends. (9)

Explain why a musical tune does not sound the same when played on different instruments. (4)

(d) Define electric field strength and give its unit of measurement. (9)

The diagram shows a negative charge of  $2 \mu\text{C}$ , positioned  $25 \text{ cm}$  away from a positive charge of  $5 \mu\text{C}$ .

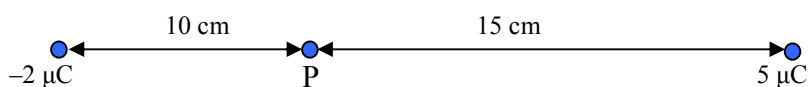

Copy the diagram into your answerbook and show on it the direction of the electric field at point P.

Calculate the electric field strength at P. (15)

Under what circumstances will point discharge occur? (4)

(permittivity of free space =  $8.9 \times 10^{-12} \text{ F m}^{-1}$ )

Blank Page